

# BELT GUARD AFTERCOOLERS

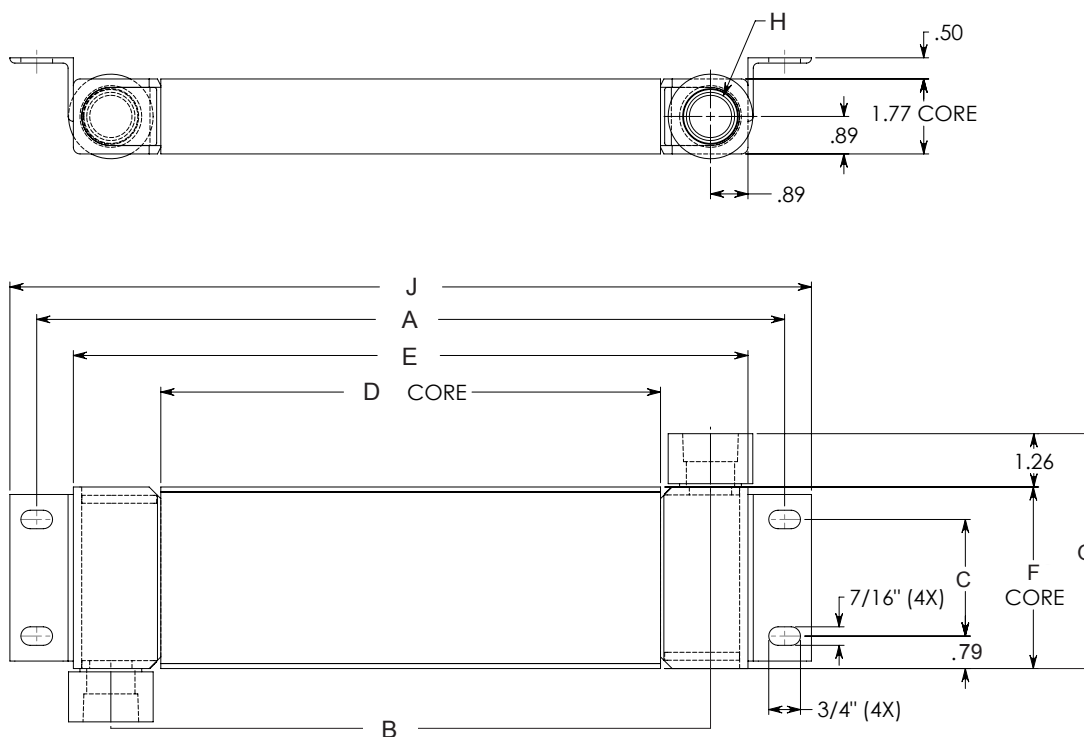

- Mount directly to compressor's belt guard, utilizing compressor pulley's air flow for cooling
- Compact aluminum bar and plate design provides maximum performance with low pressure drop
- Competitive pricing, deliveries from stock

## PRODUCT INFORMATION



MODEL NUMBER	MAX SCFM	MODEL RATING APPROACH TEMP
C-1835BG	35	5°F for 18 SCFM 15°F for 35 SCFM
C-3560BG	60	10°F for 35 SCFM 25°F for 60 SCFM
C-70100BG	100	13°F for 70 SCFM 25°F for 100 SCFM

Sizing notes, ratings are based on the following:

Max pressure rating - 250 PSI  
Max Operating Temp - 400° F  
Material - Aluminum

250° F inlet (Air)  
100-PSIG Operating Pressure  
100° F Ambient Air  
500 FPM Air Velocity  
Max Pressure Drop is 3 PSI or less

MODEL NUMBER	A	B	C	D	E	F	G	H NTP	J
C-1835BG	17.68	14.17	2.76	11.81	15.94	4.29	5.55	1.00	18.94
C-3560BG	17.68	14.17	3.94	11.81	15.94	5.51	6.77	1.00	18.94
C-70100BG	19.65	16.14	6.3	13.78	17.91	7.91	9.17	1.00	20.91